

PART NAME

NEMA 4X ENCLOSURE

PART No.

PN-1341, PN-1341-C AND PN-1341-DG

REV. DATE

11-17-08

INDUSTRY STANDARDS:

- POLYCARBONATE (LIGHT GRAY AND CLEAR)
- UL94-HB FLAMMABILITY RATING (UL FILE #E41613)
- UV STABILIZED
- SERVICE TEMPERATURE RANGE: -40°C TO +120°C
- ABS (DARK GRAY)
- UL94-HB FLAMMABILITY RATING (ULFILE #E560700)
- SERVICE TEMPERATURE RANGE: -40°C TO +80°C

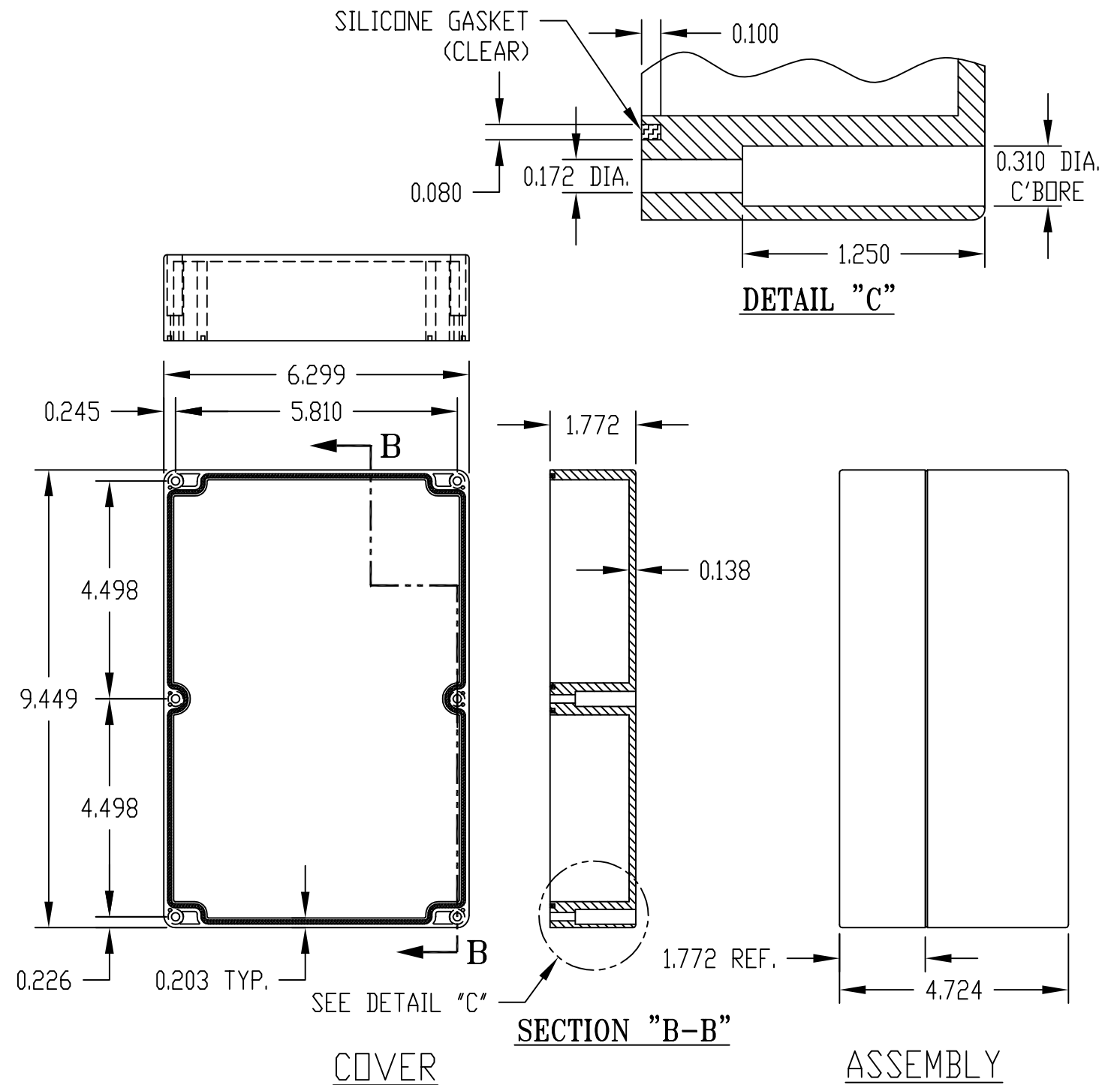
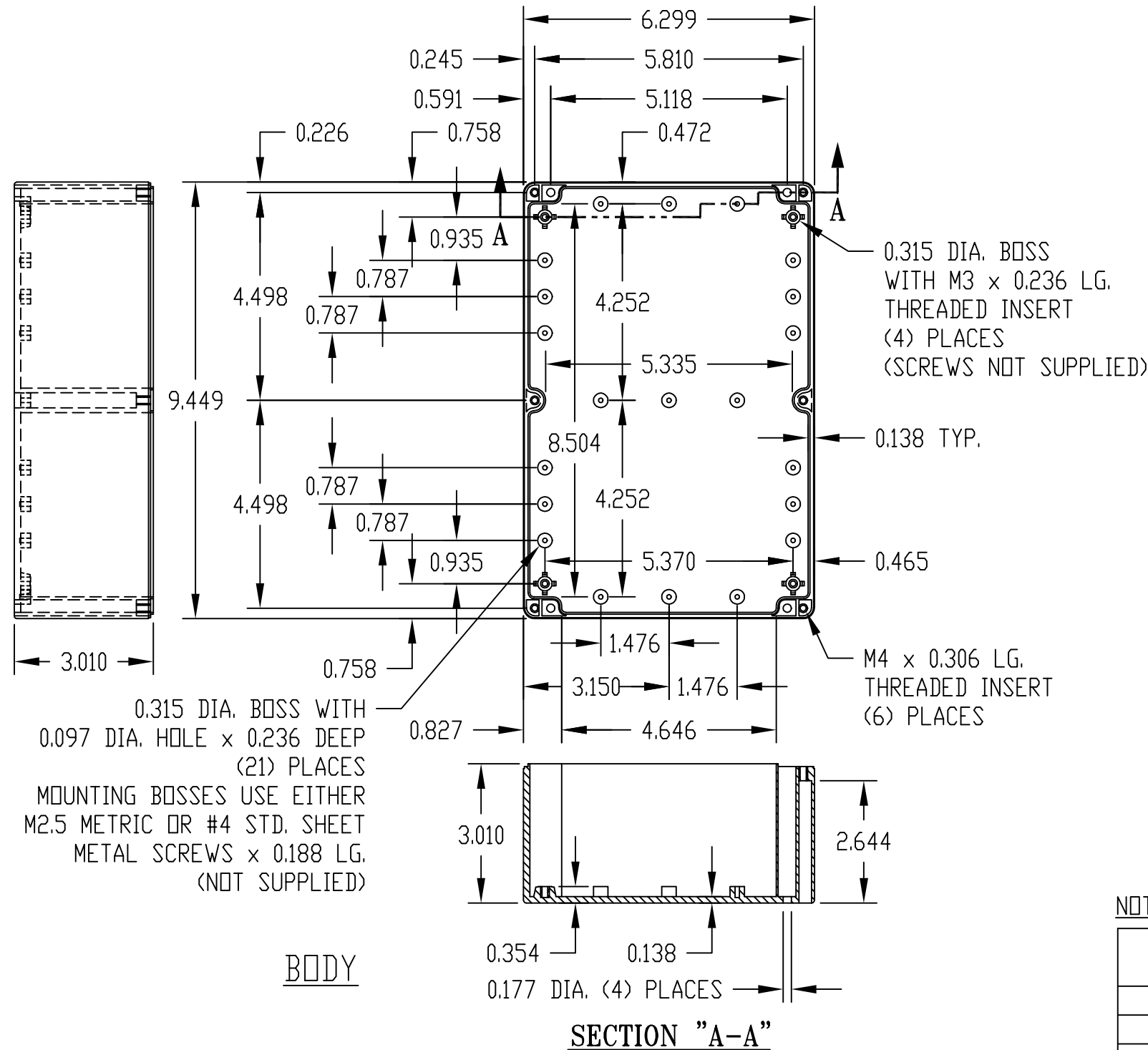

NOTE: ALL DIMENSIONS HAVE ±0.015 TOLERANCE UNLESS OTHERWISE SPECIFIED.

PART NUMBER	MATERIAL		FINISH		HARDWARE KIT
	BODY	COVER	BODY	COVER	
PN-1341	POLYCARBONATE		LIGHT GRAY		KIT CONTAINS (6) M4 x 20mm (0.787") LG. SCREWS FOR ASSEMBLY
PN-1341-C	POLYCARBONATE		LIGHT GRAY	CLEAR	
PN-1341-DG	HIGH-IMPACT ABS		DARK GRAY		